

VARIMETER Voltage Relay BA 9037

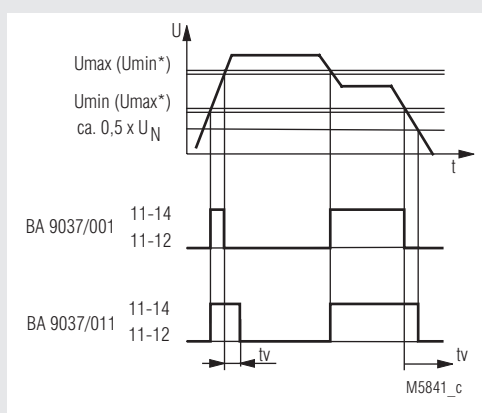

- According to IEC 255, EN 30 255, VDE 0435 part 303
- Single phase
- Measuring ranges from 24 to 660 V
- Response and release value adjustable independent of each other
- Under- and overvoltage detection
- Without auxiliary supply
- Large setting range
- With time delay
- Closed circuit operation
- Insensitive to harmonics
- LED indicators for operation and state of contacts
- Width 45 mm

Function Diagram



* U_{min} and U_{max} can also be exchanged. The hysteresis of the setting values is $< 4\%$ of the response value

Circuit Diagram

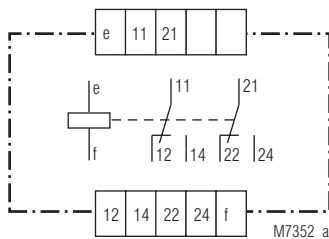

BA 9037.12

Approvals and Markings



Applications

Under- and overvoltage detection in AC or DC voltage systems

Indicators

upper LED: on, when voltage connected
lower LED: on, when output contact activated

Technical Data

Input

Nominal voltage U_N : DC 24, 42, 60 V (protected against wrong

polarity). These units are calibrated for DC voltage. When AC voltage is connected the setting has an offset of 11 %.
AC 110, 127, 230, 240, 400, 660, 690 V

Measuring ranges:

Voltage range:

Nominal consumption:

0.7 ... 1.3 U_N
0.6 ... 1.4 U_N
DC 24 V 1 W
AC 24 V 2 VA
AC 230 V 5 VA
AC 500 V 10 VA

Nominal frequency:

Frequency range:

Temperature influence:

50 / 60 Hz
 $\pm 5\%$
 $< 0.05\% / K$

Setting Ranges

Response value:

U_{min} infinite 0.7 ... 1.3 U_N
 U_{max} infinite 0.7 ... 1.3 U_N

Hysteresis:

Setting accuracy:

Repeat accuracy:

at U_{min} bzw. U_{max} < 0.96
 $< \pm 5\%$
 $< \pm 0.5\%$

Technical Data

Output

Contacts

BA 9037.12: 2 changeover contacts

Release delay: 24 V < 20 ms

220 V < 150 ms

500 V < 150 ms

5 A

Thermal current I_{th} :

Switching capacity

to AC 15

NO contact: 3 A / AC 230 V IEC/EN 60 947-5-1

NC contact: 1 A / AC 230 V IEC/EN 60 947-5-1

Electrical life IEC/EN 60 947-5-1

to AC 15 at 3 A, AC 230 V: 5 x 10⁵ switching cycles

Permissible switching frequency:

6000 switching cycles / h

Short circuit strength

max. fuse rating: 4 AgL IEC/EN 60 947-5-1

Mechanical life: > 30 x 10⁶ switching cycles

General Data

Operating mode: Continuous operation

Temperature range: - 40 ... + 70°C

Clearance and creepage distances

rated impulse voltage / pollution degree: 4 kV / 2 IEC 60 664-1

EMC

Electrostatic discharge: 8 kV (air) IEC/EN 61 000-4-2

HF irradiation: 10 V/m IEC/EN 61 000-4-3

Fast transients: 2 kV IEC/EN 61 000-4-4

Surge voltages: 1 kV IEC/EN 61 000-4-5

Interference suppression: Limit value class B EN 55 011

Degree of protection

Housing: IP 40 IEC/EN 60 529

Terminals: IP 20 IEC/EN 60 529

Housing: Thermoplastic with V0 behaviour according to UL subject 94

Vibration resistance: Amplitude 0.35 mm IEC/EN 60 068-2-6 frequency 10 ... 55 Hz

Climate resistance: 20 / 060 / 04 IEC/EN 60 068-1

Terminal designation: EN 50 005

Wire connection: 2 x 2.5 mm² solid or 2 x 1.5 mm² stranded wire with sleeve DIN 46 228-1/-2/-3/-4

Wire fixing: Flat terminals with self-lifting clamping piece IEC/EN 60 999-1

Fixing torque: 0.8 Nm

Mounting: DIN rail IEC/EN 60 715

Weight: 240 g

Dimensions

Width x height x depth: 45 x 73 x 132 mm

Classification to DIN EN 50155

Vibration and

shock resistance: Category 1, Class B IEC/EN 61 373

Protective coating of the PCB: No

Standard Type

BA 9037.12/001 AC / DC 24 V

Article number: 0030758

• without time delay

• Output: 2 changeover contacts

• Nominal voltage U_N : AC / DC 24 V

• Width: 45 mm

Variant

BA 9037.--/011:

adjustable time delay t_M 1 ... 20 sec.
If the voltage drops below 0.5 U_N the time delay is inactive, and the contacts fall back immediately.

Ordering example for variant

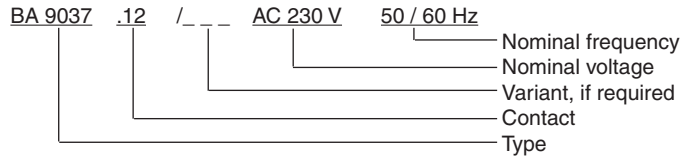

Characteristics

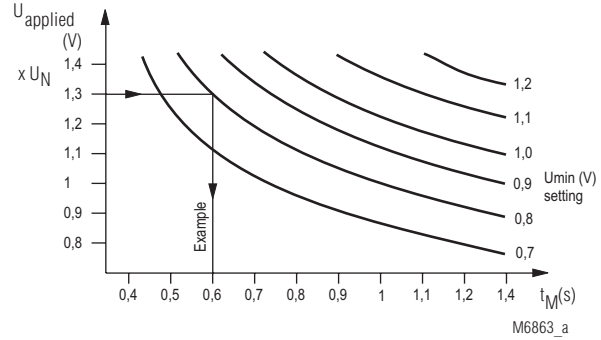

Operate delay t_M :

The diagram shows the relation of the operate delay to the applied measuring voltage $U_{applied}$ and the setting of U_{min} when the voltage is switched on. A slow voltage change reduces the delay.